



DRESSTA®

TD-15M HS

CRAWLER DOZER

STD-LT-WT-LGP



■ **Net Horsepower**
150 kW (201 hp)

■ **Blade Capacity**
up to 5.95 m³ (7.8 yd³)

■ **Operating Weight**
20320 kg (44,797 lb) STD
20460 kg (45,106 lb) LT
20965 kg (46,219 lb) WT
21270 kg (46,892 lb) LGP

Specification

ENGINE

* Make and Model	Cummins QSB6.7
Type	In-line, 4-cycle, water-cooled, 6-cylinder Electronic controls (ECM), Diesel Particulate Filter (DPF)
Aspiration	Turbocharged and CAC
Fuel system	HPCR Electronic
Gross Horsepower, SAE J1995	164 kW (220 hp)
Net Horsepower, SAE J1349/ISO 9249	150 kW (201 hp)
Rated rpm	2000 rpm
Max. torque @ 1450 rpm	949 Nm (700 ft-lb)
Displacement	6.7 l (408 in ³)
Bore and Stroke	107 x 124 mm (4.21" x 4.88")
Air cleaner	dry type, dust pre-separation block with exhaust aspirated primary, filter elements and service indicator

Meets EU Stage IIIB and EPA Tier 4 interim emission regulations

TRANSMISSION & TORQUE CONVERTER

3-speed transmission, modular, countershaft type power shift, electro-hydraulic control. Preset travel speed selection and auto-downshift.

Single stage 370 mm (14.6") torque converter with a 2.6:1 stall ratio drives to transmission through a double universal joint.

TRAVEL SPEEDS

Gear	Forward		Reverse	
	km/h	(mph)	km/h	(mph)
1 st	4.0	(2.5)	4.7	(2.9)
2 nd	7.1	(4.4)	8.2	(5.1)
3 rd	10.8	(6.7)	12.6	(7.8)

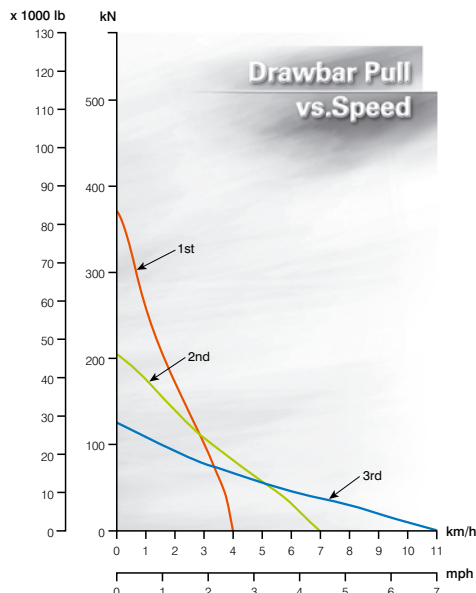

STEERING SYSTEM

The hydrostatic steering system (HSS) offers fast response and more precise turning. Both tracks are powered without interruption allowing smooth, continuous turns and powerful and productive dozing even on soft ground or on slopes. The left hand joystick controls transmission and steering drive for up and down shifting and steering.

BRAKES

Foot pedal applies both brakes for parking and downhill control. Brakes are spring applied and hydraulically released.

FINAL DRIVES

Double-reduction module provides desired gear reduction at the sprocket. Ring-type sprocket distributes wear evenly over track bushings, letting every tooth ride free one-half of the time to reduce wear. Final drives or sprockets are replaceable without removing track frames.

TRACK FRAME

All-welded heavy box section track frame is kept in alignment with track frame guides providing true vertical oscillation.

Track rollers, each side STD (LT, WT, LGP)	6 (8)
Top idlers, each side	2
Front idlers (drum type)	1
All rollers and idlers	lifespan lubricated
Oscillation at center of front idler (STD)	293 mm (11.52")
Oscillation at center of front idler (LT, WT, LGP)	353 mm (13.9")

TRACKS

Lubricated Track System (LTS) virtually eliminates internal pin and bushing wear through use of a patented seal assembly.

The split master link reduces chain removal and installation time.

	STD	LT	WT	LGP
Track shoe width, standard	508 mm (20")	508 mm (20")	762 mm (30")	940 mm (37")
Track shoes, each side	39	43	43	43
Ground contact area	2.7 m ² (4,160 in ²)	3.1 m ² (4,800 in ²)	4.6 m ² (7,200 in ²)	5.7 m ² (8,880 in ²)
Ground pressure (w/std. equipment)	75.4 kPa (10.9 psi)	65.8 kPa (9.5 psi)	44.9 kPa (6.5 psi)	36.9 kPa (5.4 psi)
Height of grouser	64 mm (2.52")			
Ground clearance	445 mm (17.5")			

REFILL CAPACITIES

	Liter	(US gal)
Fuel tank	388	(102.5)
Cooling system	27	(7.1)
Crankcase w/filters	18.5	(4.9)
Transmission system	153	(40.4)
Differential & final drive, each	40	(10.6)
Hydraulic reservoir	60	(16)

OPERATING WEIGHT

Includes standard equipment and full fuel.

	STD	LT	WT	LGP
Type of blade	Semi-U	Semi-U	Semi-U	Straight
Canopy ROPS	20320 kg (44,797 lb)	20460 kg (45,106 lb)	20965 kg (46,219 lb)	21270 kg (46,892 lb)
Cab ROPS	20860 kg (45,988 lb)	21010 kg (46,319 lb)	21515 kg (47,432 lb)	21820 kg (48,104 lb)

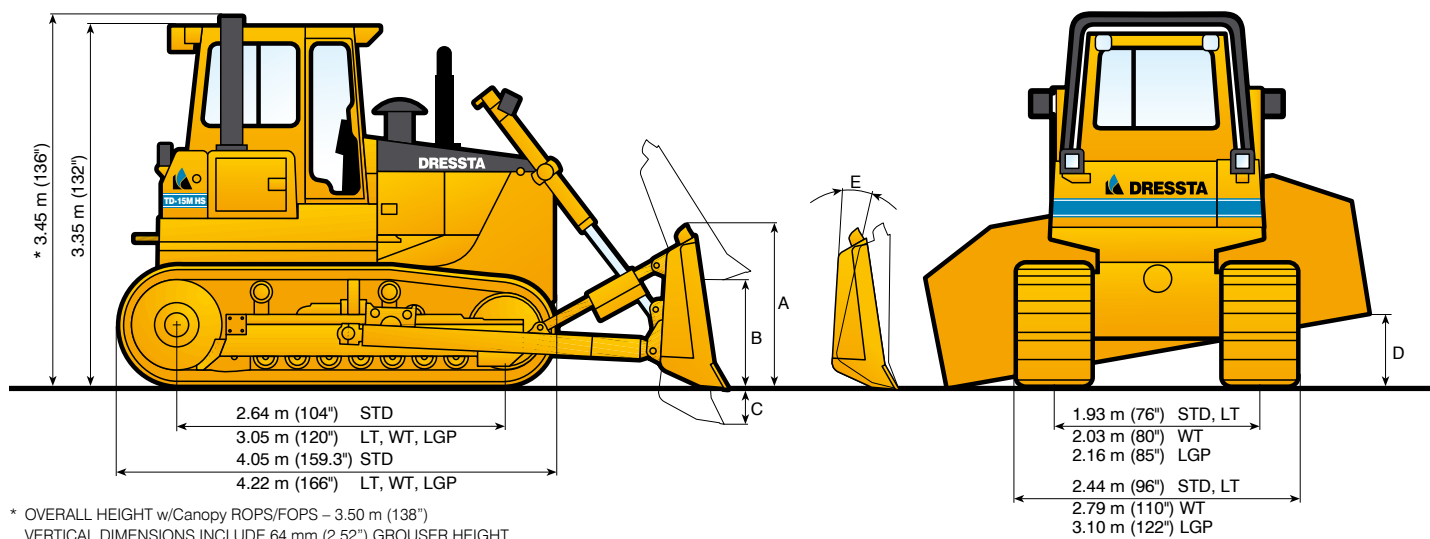

OVERALL DIMENSIONS WITH EQUIPMENT

	UNDRRCARRIAGE	BLADE SELECTION					
		SEMI-U	ANGLE	6-WAY	SEMI-U	6-WAY	STRAIGHT
Length with blade, and drawbar	STD	5.23 m (17'2")	5.39 m (17'8")	—	—	—	—
	LT	5.67 m (18'7")	5.83 m (19'2")	—	—	—	—
	WT	—	—	5.87 m (19'3")	5.67 m (18'7")	—	—
	LGP	—	—	—	—	5.87 m (19'3")	5.52 m (18'1")
Length with blade, and multi-shank ripper	STD	6.48 m (21'3")	6.55 m (21'6")	—	—	—	—
	LT	6.91 m (22'8")	6.99 m (22'11")	—	—	—	—
	WT	—	—	7.03 m (23'1")	6.94 m (22'9")	—	—
Length with blade and single-shank ripper	STD	6.25 m (20'6")	6.40 m (21')	—	—	—	—
	LT	6.76 m (22'2")	6.84 m (22'5")	—	—	—	—
	WT	—	—	6.88 m (22'7")	6.79 m (22'3")	—	—
Width, blade angled	STD<	—	3.75 m (12'4")	—	—	—	—
	WT	—	—	3.33 m (10'11")	—	—	—
	LGP	—	—	—	—	3.51 m (11'6")	—
Width over trunnions	STD<	2.81 m (9'3")	2.81 m (9'3")	—	—	—	—
	WT	—	—	—	2.91 m (9'7")	—	—
	LGP	—	—	—	—	—	3.34 m (10'11")
Width over „C“ frame	STD<	—	3.82 m (12'6")	—	—	—	—

BLADE SPECIFICATIONS

UNDRRCARRIAGE	STD<	STD<	WT	WT	LGP	LGP	
BLADE SELECTION	SEMI-U	ANGLE	6-WAY	SEMI-U	6-WAY	STRAIGHT	
Track shoes	20"/22"/24"/26"	20"/22"/24"/26"	20" or 22"	30"/26"/24"/22"/20"	26"	37"	
Blade capacity, SAE J1265	5.7 m ³ (7.45 yd ³)	3.8 m ³ (5 yd ³)	3.8 m ³ (5 yd ³)	5.95 m ³ (7.8 yd ³)	4.0 m ³ (5.2 yd ³)	3.6 m ³ (4.7 yd ³)	
Blade dimensions: – width over end bits – height	A	3.44 m (135") 1.46 m (58")	4.13 m (163") 1.12 m (44")	3.68 m (145") 1.36 m (53.5")	3.59 m (141") 1.46 m (58")	3.83 m (151") 1.36 m (53.5")	3.86 m (152") 1.10 m (43")
	B	STD 1104 mm (43.5") LT 1102 mm (43.4")	STD 1102 mm (43.4") LT 1119 mm (44")	1280 mm (50.4")	1102 mm (43.4")	1280 mm (50.4")	1240 mm (49")
Max. drop below ground level	C	463 mm (18.2")	STD 552 mm (21.7") LT 542 mm (21.3")	692 mm (27")	463 mm (18.2")	692 mm (27")	455 mm (18")
Max. tilt adjustment	D	724 mm (28.5")	385 mm (15.2")	450 mm (18")	782 mm (30.8")	466 mm (18.3")	698 mm (27.5")
Blade angle, either side		—	25°	23.5°	—	23.5°	—
Max. pitch adjustment	E	9°	—	8°	9°	8°	9°
Weight of blade equipment		2670 kg (5,886 lb)	2700 kg (5,952 lb)	2575 kg (5,677 lb)	2760 kg (6,085 lb)	2625 kg (5,787 lb)	2740 kg (6,040 lb)

RIPPER SPECIFICATION

RIPPER SELECTION	MULTI-SHANK	SINGLE-SHANK
Tool Beam		
Overall width	2230 mm (88")	1100 mm (43")
Cross section (height x width)	229 x 254 mm (9" x 10")	269 x 284 mm (10.6" x 11.2")
Ground clearance under tool beam: – ripper raised – ripper lowered	1023 mm (40.3")	995 mm (39")
	108 mm (4.3")	80 mm (3")
Shanks		
Number of shanks per ripper, max.	3	1
Spacing center to center	1015 mm (40")	—
Penetration, max.	600 mm (24")	713 mm (28")
Ground clearance, max. raised	455 mm (17.9")	485 mm (19")
Shank positions (vertical)	2	2
Weight		
Complete, including one shank	1554.5 kg (3,427 lb)	1546 kg (3,408 lb)
Each additional shank	94.5 kg (208 lb)	—
Penetration Force	64 kN (14,387 lb)	71.04 kN (15,970 lb)
Pryout Force	268.7 kN (60,404 lb)	390.9 kN (87,874 lb)

TD-15M HS

CRAWLER DOZER

STD-LT-WT-LGP



HYDRAULIC CONTROL SYSTEM

Pump, tandem gear, driven from torque converter.

Output @ rated engine rpm 173 l/min (46 gpm)

Relief valve setting..... 17.2 MPa (2,500 psi)

Cylinders, bore and stroke:

lift (STD) 101.6 x 1233.5 mm (4" x 48.6")

lift (LT, WT, LGP) 101.6 x 1095 mm (4" x 43.1")

tilt 139.7 x 147 mm (5.5" x 5.8")

tilt/pitch 139.7/152.4 x 147 mm (5.5"/6" x 5.8")

STANDARD EQUIPMENT

- Air cleaner, dry type with exhaust aspirated primary and safety elements and service indicator
- Alarm, back-up
- Alternator, 70 A
- Antifreeze, -37°C (-34°F)
- Batteries, (2) 12 V, 815 CCA, maintenance free
- Brakes, foot, spring applied, hydraulically released
- Canopy, 2 post ROPS/FOPS (SAE J1040, J231)
- Coolant filter conditioner
- Cooling module; includes radiator, transmission oil cooler, charge air cooler; isolation mounted
- Decelerator – right foot pedal and brake – center foot pedal
- Diagnostic centers for power train and equipment hydraulic pressures
- Ecological drains for engine oil, radiator coolant and hydraulic oil
- Engine hood, solid, sloped
- Engine side doors, hinged, perforated type
- Exhaust pipe extension with elbow
- Fan, blower
- Filters engine oil, full flow and by-pass with replaceable "spin-on" elements
- Filters, power train
- Final drive seal guard
- Fuel strainer
- Guards: crankcase, hinged, with front pull hook, transmission, fan, radiator and sprocket rock and dirt deflector
- Hitch, retrieval
- Horn, electric
- Hydraulic controls, pilot operated, 3-spool valve, 3 rd section plugged, 1 lever (lift/tilt)
- Instruments:
 - Gauges: fuel level, engine coolant temp., engine oil pressure, torque converter oil temp., voltmeter, hourmeter, brake lock
 - Warning lights: air cleaner filter, transmission oil filter, hydraulic oil filter, transmission/clutch oil low pressure
 - Audible & visual warning system: low engine coolant level, low engine oil pressure
- Lights with guards, 2F – lift cylinders, 2R – fuel tank mounted
- Muffler, under engine hood, insulated
- Radiator guard door, hinged, louvered
- Rear access platform
- Receptacle, starting/charging
- Seat belt (SAE J386) – 3" wide, retractable
- Seat, deluxe, air suspension type, vinyl cover, adjustable with arm rests, swivel 14° to right
- Starting, 24 V
- Starting aid – air grid heater
- Steering, hydrostatic type, left hand single lever control (joystick)
- Tools compartment
- Torque converter, single stage
- Transmission power shift, 3 speeds forward, 3 reverse, preset travel speed selection and auto-downshift
- Water separator, fuel system
- UNDERCARRIAGE
 - Track frames, oscillating type, lifespan lubricated rollers and idlers
 - Track adjusters, hydraulic
 - Track chain end guides, integral
 - STANDARD (STD)
 - Track chain, sealed and lubricated (LTS) with split master link, 39 links
 - Track frame, 6 roller, 1930 mm (76") gauge
 - Track shoes, 508 mm (20") severe service
 - LONG TRACK (LT)
 - Track chain, sealed and lubricated (LTS) with split master link, 43 links
 - Track frame, 8 roller, 1930 mm (76") gauge
 - Track shoes, 508 mm (20") severe service
 - WIDE TRACK (WT)
 - Track chain, sealed and lubricated (LTS) with split master link, 43 links
 - Track frame, 8 roller, 2030 mm (80") gauge
 - Track shoes, 762 mm (30") severe service
 - LOW GROUND PRESSURE (LGP)
 - Track chain, sealed and lubricated (LTS) with split master link, 43 links
 - Track frame, 8 roller, 2160 mm (85") gauge
 - Track shoes, 940 mm (37") extreme clipped corner with bolt holes for 3 rd rail track
 - Track chain center guides

OPTIONAL ATTACHMENTS

- AM/FM CD radio
- Batteries, cold start (2) 12 V, 960 CCA
- Blade Equipment (STD & LT):
 - Semi-U Dozer, 5.7 cu. m (7.45 cu. yd) with hydraulic tilt
 - Hydraulic tilt/pitch
 - Angle Dozer (manual angle), 3.8 cu. m (5 cu. yd) with hydraulic tilt
- Blade Equipment (WT):
 - Semi-U Dozer, 5.95 cu. m (7.8 cu. yd) with hydraulic tilt
 - Hydraulic tilt/pitch
 - Angle Dozer (6-way), 3.8 cu. m (5 cu. yd) full hydraulic, inside arm with hydraulic tilt, angle and manual pitch
- Blade Equipment (LGP):
 - Straight Dozer, 3.6 cu. m (4.7 cu. yd) with hydraulic tilt
 - Angle Dozer (6-way), 4.0 cu. m (5.2 cu. yd) full hydraulic
- Cab and ROPS Equipment:
 - Air conditioner/heater/pressurizer/defroster, underseat mounted; A/C condenser behind roof
 - Cab w/sound suppression, 4 wipers w/washers, inside mirror, dome light, tinted safety glass and air recirculation system
 - Heater /pressurizer/ defroster
 - ROPS for cab or forestry attachment
 - Sun visor in cab
 - Sweeps, forestry, front and rear
 - Screen rear (includes deduct for standard rear access platform)
 - Seat, air suspension, fabric cover (for use w/cab)
 - Drawbar, fixed
 - Engine enclosures: perforated hood and perforated side doors
 - Exhaust pipe extension w/guard, for sweeps
 - Guards:
 - Crankcase, severe service w/front pull hook
 - Final drive, rock (STD, LT, WT)
 - Tank guard, bolted (includes deduct for rear access platform)
 - Track roller, full length
 - Transmission, severe service
 - Hydraulic controls, pilot operated:
 - 3-spool valve (3 rd section plugged), 1 lever (for use with 6-way or tilt-pitch)
 - 3-spool valve, 2 lever (for use w/ripper and tilt/tilt-pitch or 6-way)
 - Inspection lamp, 24 V, portable with 6 m (20') cable
 - Instrument panel guard (for use w/Canopy ROPS/FOPS)
 - Lights for Canopy ROPS/FOPS, 2F–2R
 - Lights for cab, 2F–2R
 - Lights for cab and sweeps, 2F–2R
 - Lights, 2F, ROPS mounted, for use with cab, (not for use with sweeps)
 - Mirrors, 2 pcs. exterior (for use w/cab)
 - Ripper, multi-shank, max. 3 shanks
 - Ripper, single-shank
 - Screening pkg; cab for screens installation must be ordered:
 - Screens for cab windows (front, rear, side and doors)
 - Screens for tractor and cab lights
 - Sound suppression package (CE requirements)
 - Starting/charging receptacle plug assembly
 - Third rail track system (LGP)
 - Tools in metal box
 - Track shoes, set of 78, severe service (STD) 560 mm (22"), 610 mm (24"), 660 mm (26")
 - Track shoes, set of 86, severe service (LT) 560 mm (22"), 610 mm (24"), 660 mm (26")
 - Track shoes, set of 86, severe service (WT) 508 mm (20"), 560 mm (22"), 610 mm (24"), 660 mm (26"), not for use with Angle Dozer (6-way)
 - Track shoes, set of 86, severe service (LGP) 660 mm (26"), for use with Angle Dozer (6-way)
 - Vandalism protection

Specifications subject to change without notice. Illustrations and pictures may include optional attachments and accessories and may not include all standard equipment.

DRESSTA Co.Ltd.

Kwiatkowskiego 1, 37-450 Stalowa Wola, POLAND
 tel.: +48 15 813 5252, 15 813 4556 fax: +48 15 813 4763
 sales@dressta.com.pl www.dressta.com.pl