



CRAWLER DOZERS

TD-7R TD-8R TD-9R TD-10R



The Dresst

Represents significant and me

Non-reflective paint on hood, radiator guard and ROPS/Cab hood

Heavy duty louvered radiator guard door

Efficient cooling module with radiator, power train cooler and charge air cooler

Steps and handrails provide easier entry

Modern styled square shaped ROPS Canopy w/headlining and mirror

Cab equipped machines offer an optional air conditioner/heater/pressurizer. A/C condenser behind roof mounted for added serviceability

Cummins engines meet Tier 3 emission requirements



TD-7R

TD-8R

Reliable and pro

ta R-series

Meaningful improvements



Single lever joystick controls
all machine motion functions

Comfortable suspension seat
w/lumbar support
Arm rests are adjustable for height
without needing tools

Safety lever neutralizes joystick
function and also applies
parking brakes

Brakes are spring applied
and hydraulic released

Rear fuel tank guard included
as standard, on all models

Power train diagnostic service
panel, also includes brake
release ports

TD-9R TD-10R

productive dozers

Operator's e

Roomy, comfortable and ergonomically designed operator's compartment assures maximum productivity

- The suspension seat with adjustable arm rests provides the best position and maximum comfort.
- Efficient and operator-friendly left hand joystick controls all machine motion functions.
- The instrument panel includes a full complement of gauges and indicator lights that provide the operator the information necessary to operate efficiently and effectively.
- The right foot pedal controls engine deceleration and brake for stopping or holding the machine. The left foot pedal provides braking.
- The combination of the ergonomically designed joystick and well located foot pedal controls provides the operator unsurpassed operating ease.



TD-7R

TD-8R

Environment

Highly organized operator compartment
by reducing operator's fatigue



ROPS system

Excellent operator protection is provided by the four post ROPS with extension of the front roof and sound absorbing pad. Forestry sweeps and screening packages are designed to provide operator protection in various types of forestry applications.

Cab

An optional hexagonal, sound suppressed cab provides an unsurpassed work environment for the operator. It can be also equipped with air conditioner/heater/pressurizer.

Lighting

Three halogen lights are offered as standard equipment. Front lights are protected by the roof overhang.

TD-9R TD-10R

Power train



- Rugged and powerful Cummins engine provides outstanding power, easy service and high reliability.
- A torque converter helps operator to perform complicated tasks with greater ease.
- Full power shift, countershaft type, electro-hydraulically actuated transmission provides smooth, low shock shifting.
- Proven and well accepted clutch-brake steering system provides excellent steering modulation and long life.
- Final drives employ a pinion and bull gear speed reduction.

TD-7R

TD-8R

ability

Dependable undercarriage

- The track frames incorporate high strength steel full box section side members welded together into a rigid foundation.
- Standard Lubricated Track System (LTS) virtually eliminates internal pin and bushing wear.
- Split Master Link reduces installation time and simplifies repairs.
- The top idlers incorporate long-life heavy duty tapered roller bearings for added reliability and durability.
- Metal-to-metal seal of track rollers keep lubrication in and dirt out.



TD-9R TD-10R

Product

Outstanding performance

Unique power train, designed for small crawler applications, provides the customer with outstanding performance in all aspects of working capabilities:

- Fine machine control
- Slow turns
- Quick pivoting turns
- Operating at full power pushing heavy loads
- Finish grading



TD-7R

TD-8R

ctivity

Six-Way Blade



The six-way hydraulic Power Angle Tilt (PAT) blade system is designed to improve performance, provide better wear resistance, increase strength and serviceability. This system also reduces maintenance, allows transport within 8'6" widths limits and provides long wear.

The cutting edge angles and blade moldboard geometry are designed to provide an exceptional balance between fine-light dozing and aggressive heavy material movement, enabling R-Series dozers to perform better over a broader variety of dirtmoving applications.

A single lever T-type control operates the equipment control valve and is shaped to fit comfortably into the operator's right hand.

The blade responds quickly, giving the operator a true feel for the blade and provides precise grading efficiency.



TD-9R TD-10R

Service

Low main



TD-7R

TD-8R

Availability

Maintenance



The design philosophy of the R-series has been to reduce daily and weekly maintenance and increase uptime.

Futhermore, sight gauges and ground level access dipstick make fluid level checks quick and effortless.

- Blade equipment service requirements are minimized through sealed, permanently lubricated, non-metallic bushings and chrome plated pins at all cylinder pivot connections. There are only two lubrication points on the blade system.
- A hydraulic reservoir with sight gauge which is visible from the side for daily walk around inspections.
- A large, single top hood door provides ready access to the radiator fill, engine oil fill and check or reversible fan blades (optional).
- No tools are required for access to the power train spin-on filter located in the left-hand compartment next to the operator's seat. This location also contains power train diagnostic center, the battery, storage area and steering and transmission control valve assembly.
- The right side of reservoir housing features an area for the spin-on equipment hydraulic oil filter, hydraulic system pressure check port, hydraulic oil fill port and the power train oil level dipstick and fill ports.
- Both doors, left and right, are hinged and lockable.



TD-9R TD-10R

Specification

ENGINES

	TD-7R	TD-8R	TD-9R	TD-10R
Power (SAE Net)	55 kW (74 hp) @ 2200 rpm	58 kW (78 hp) @ 2600 rpm	69 kW (93 hp) @ 2200 rpm	76 kW (101 hp) @ 2500 rpm
Model	Cummins QSB3.3	Cummins QSB3.3	Cummins QSB3.3	Cummins QSB4.5
Aspiration	Turbocharged and CAC	Turbocharged and CAC	Turbocharged and CAC	Turbocharged and CAC
Displacement	3.3 l	3.3 l	3.3 l	4.5 l
Bore and stroke	95 x 115 mm	95 x 115 mm	95 x 115 mm	102 x 137 mm
Max. torque	371 Nm @ 1400 rpm	371 Nm @ 1400 rpm	414 Nm @ 1600 rpm	488 Nm @ 1500 rpm

Meet EPA Tier 3 emission regulations

TRANSMISSION & TORQUE CONVERTER

Countershaft type, full power shift, electro-hydraulically actuated transmission with 3 speeds forward and 3 reverse. Joystick control valve has electric transmission range shift control for up and down shifting.

Single stage, 280 mm torque converter drives to transmission through a permanently lubricated double universal joint.

FINAL DRIVES

Single stage final drives employ a pinion and bull gear speed reduction to increase torque for high drawbar pull.

Reduction ratios: 5.08:1 (TD-7R), 5.66:1 (TD-8R) and 8.1:1 (TD-9R and TD-10R).

STEERING AND BRAKING

DRESSTA caliper type clutch/brake system provides excellent steering modulation over any range of quick or broad steering changes.

The left hand joystick controls transmission and steering drive.

Right foot pedal applies decelerator and brake for parking, left pedal applies disc brakes for downhill speed control.

CAPACITIES

	TD-7R-8R-9R	TD-10R		TD-7R-8R-9R	TD-10R
Fuel tank	170.0 l	170.0 l	Transmission & steering drive	65.0 l	70.0 l
Cooling system	15.2 l	18.5 l	Final drive, each side	9.5 l	15.1 l
Crankcase	7.0 l	11.0 l	Hydraulic reservoir	51.1 l	51.1 l

DRAWBAR PULL

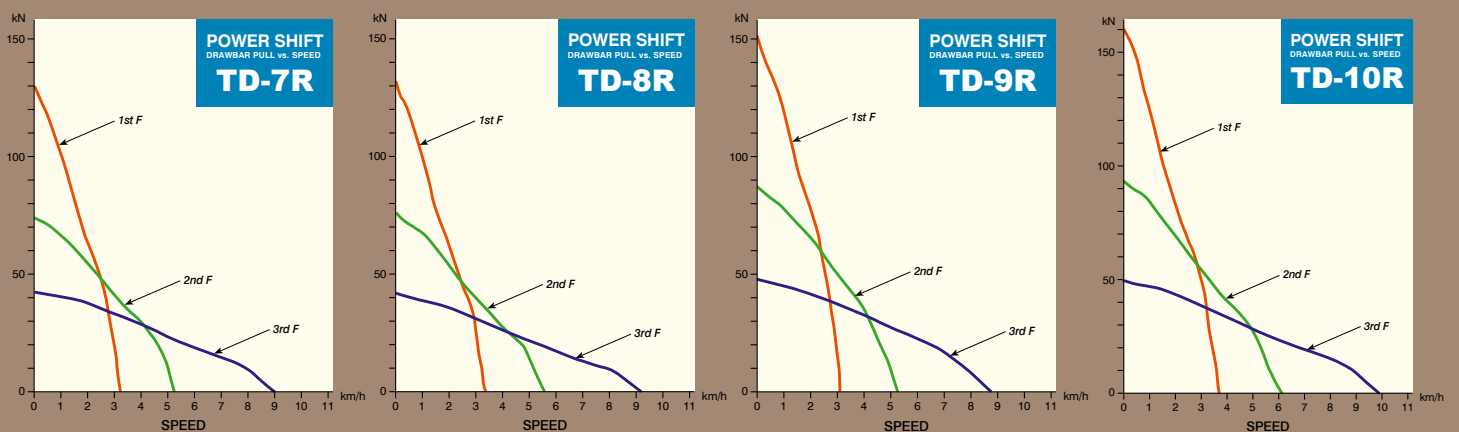

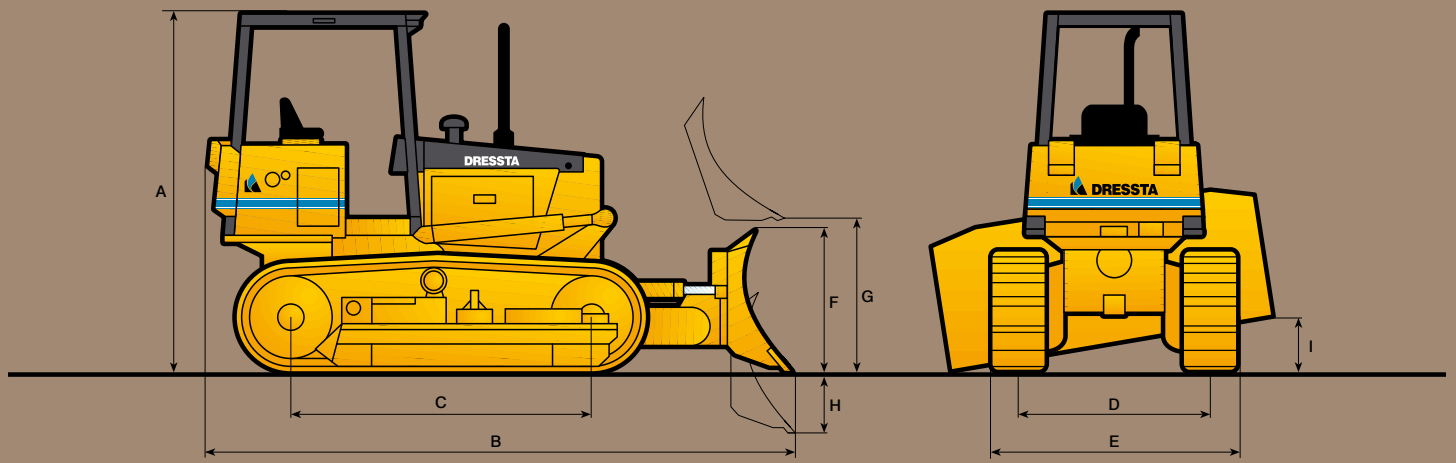

DIMENSIONS

TD-7R

TD-8R

	STD	LT	LGP	STD	LGP
A Overall height with ROPS	2.72 m	2.72 m	2.72 m	2.72 m	2.72 m
Overall height with Cab	2.70 m	2.70 m	2.70 m	2.70 m	2.70 m
B Overall length w/blade	3.59 m	4.02 m	4.02 m	4.31 m	4.31 m
C Track on ground	1.83 m	2.08 m	2.08 m	2.08 m	2.08 m
D Gauge	1.37 m	1.37 m	1.55 m	1.37 m	1.55 m
E Width over tracks	1.75 m	1.75 m	2.16 m	1.75 m	2.16 m

BLADE SPECIFICATIONS

Blade capacity (SAE)	1.4 m ³	1.4 m ³	1.45 m ³	1.68 m ³	1.45 m ³
F Height	0.84 m	0.84 m	0.84 m	0.94 m	0.84 m
Width	2.62 m	2.62 m	2.84 m	2.62 m	2.82 m
G Max lift	0.94 m	0.89 m	0.89 m	0.89 m	0.89 m
H Digging depth	0.45 m	0.44 m	0.44 m	0.44 m	0.44 m
I Tilt adjustment	0.39 m	0.39 m	0.42 m	0.39 m	0.42 m
Blade angle	25°	25°	25°	25°	25°

UNDERCARRIAGE

	STD	LT	LGP	STD	LGP
Track shoe width	381 mm	381 mm	610 mm	381 mm	610 mm
Track shoes (each side)	34	37	37	37	37
Ground contact area	1.4 m ²	1.59 m ²	2.54 m ²	1.59 m ²	2.54 m ²
Ground pressure	54 kPa	49.6 kPa	32.2 kPa	50.5 kPa	32.9 kPa
Track rollers (each side)	5	6	6	6	6
Strutted track link pitch	165 mm	165 mm	165 mm	165 mm	165 mm
Height of grouser	53.5 mm	53.5 mm	53.5 mm	53.5 mm	53.5 mm
Minimum ground clearance	323 mm	323 mm	323 mm	323 mm	323 mm

Operating Weight

Includes standard equipment, blade and full fuel.

Canopy ROPS/FOPS	7685 kg	8034 kg	8334 kg	8180 kg	8516 kg
Cab ROPS/FOPS	7980 kg	8329 kg	8629 kg	8475 kg	8811 kg

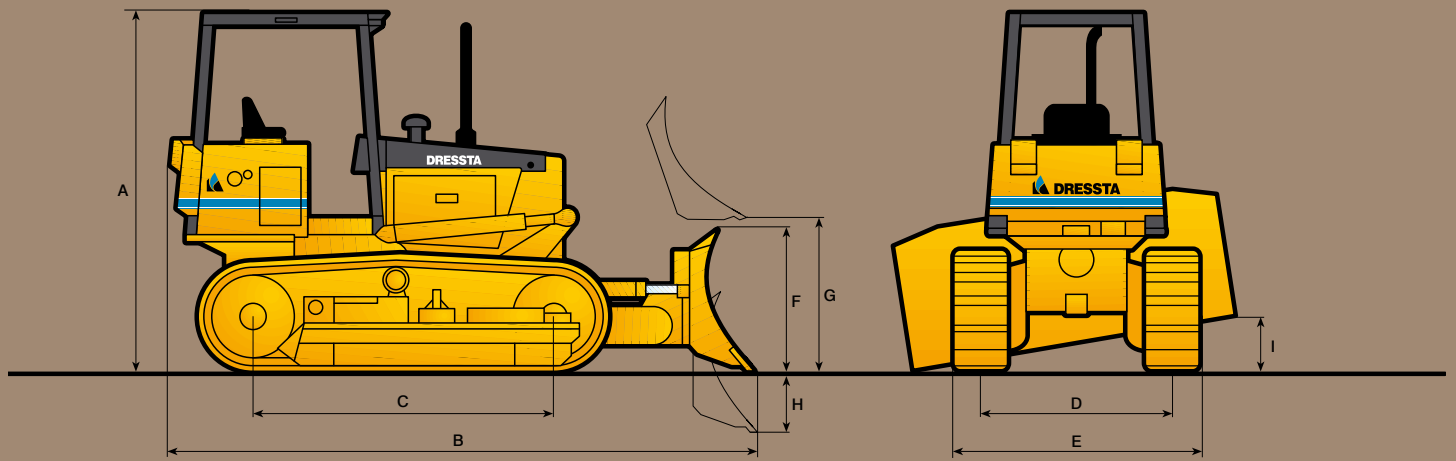

DIMENSIONS

TD-9R

TD-10R

	STD	LGP	STD	LGP
A Overall height with ROPS	2.72 m	2.72 m	2.72 m	2.72 m
Overall height with Cab	2.76 m	2.76 m	2.76 m	2.76 m
B Overall length w/blade	4.41 m	4.41 m	4.48 m	4.48 m
C Track on ground	2.19 m	2.19 m	2.19 m	2.27 m
D Gauge	1.58 m	1.58 m	1.68 m	1.68 m
E Width over tracks	2.03 m	2.19 m	2.19 m	2.29 m

BLADE SPECIFICATIONS

	STD	LGP	STD	LGP
Blade capacity (SAE)	1.87 m ³	1.76 m ³	2.15 m ³	2.21 m ³
F Height	0.99 m	0.95 m	0.99 m	0.99 m
Width	2.69 m	2.82 m	2.97 m	3.05 m
G Max lift	0.87 m	0.87 m	0.87 m	0.87 m
H Digging depth	0.42 m	0.42 m	0.42 m	0.42 m
I Tilt adjustment	0.40 m	0.42 m	0.44 m	0.45 m
Blade angle	25°	25°	25°	25°

UNDERCARRIAGE

	STD	LGP	STD	LGP
Track shoe width	457 mm	610 mm	508 mm	610 mm
Track shoes (each side)	39	39	39	40
Ground contact area	1.99 m ²	2.67 m ²	2.22 m ²	2.77 m ²
Ground pressure	44.8 kPa	34.2 kPa	40.8 kPa	33.1 kPa
Track rollers (each side)	6	6	6	6
Strutted track link pitch	165 mm	165 mm	165 mm	165 mm
Height of grouser	53.6 mm	53.6 mm	53.6 mm	53.6 mm
Minimum ground clearance	381 mm	381 mm	381 mm	381 mm

Operating Weight

Includes standard equipment, blade and full fuel.

Canopy ROPS/FOPS	9115 kg	9291 kg	9230 kg	9343 kg
Cab ROPS/FOPS	9410 kg	9586 kg	9525 kg	9638 kg

7R 8R 9R 10R

Engine

- Meets EPA Tier 3 emission regulations
- Turbocharged and CAC, direct injection
- Water separator, fuel system
- Engine coolant radiator
- Engine coolant, to -37°C
- Starting aid – air grid heater
- Fan, blower type
- Fan, reversible
- Muffler, underhood
- Exhaust pipe and elbow
- Exhaust pipe, forestry
- Exhaust resonator
- Air cleaner, dry type
- Spin-on engine oil and fuel filters
- Fuel strainer
- Engine speed control knob

Power Train

- Torque converter, single stage
- Transmission, full power shift, 3F - 3R
- Steering, single stage, planetary
- Single lever control, left joystick w/safety lever
- Final drive, single stage, spur-gear
- Transmission oil cooler, air-to-oil
- Diagnostic check panel with brake release port
- Decelerator/brake, right pedal, brake pedal lock button
- Brake, left pedal

Electrical

- 12 V system
- Battery, 815 CCA, maintenance free
- Battery, 960 CCA, cold start
- Alternator 105/120 A
- Horn
- Alarm back-up, with guard, 2-level sound
- Lights with guards, halogen type, 2F – 1R

Hydraulic system

- Hydraulic reservoir with sight gauge
- Oil filter service indicator
- 3-spool valve, low-effort "T" control
- 4-spool valve, 2 levers

Undercarriage

- Track frame, rigid type, STD
- Track frame, rigid type, LT
- Track frame, rigid type, LGP
- Front and rear chain guides

7R 8R 9R 10R

Undercarriage

- Track frame covers
- Track chains, sealed and lubricated (LTS)
- Track adjusters, hydraulic
- Rollers and idlers, lifespan lubricated
- Split master links
- Rock deflector
- Track shoes, standard: 381 mm (TD-7R & TD-8R), 457 mm (TD-9R), 508 mm (TD-10R)
- Track shoes, optional
- Track roller guards

Operator's station

- Canopy ROPS/FOPS (SAE J1040, J231) with roof extension and roof headliner
- Cab ROPS/FOPS (SAE J1040, J231) with sound suppression
- Air conditioner/heater/pressurizer/defroster
- Heater/pressurizer/defroster
- Seat, suspension type, adjustable with arm rests
- Seat belt (SAE J386), 76 mm, retractable
- Instrument panel
- Gauges and warnings lights
- Footrests
- Rear view mirror
- Mirrors, 2 pcs, for use with cab

Protection

- Sweeps front
- Screen rear
- Screening package for forestry applications
- Vandalism protection

Blade equipment and attachments

- Angle dozer inside arm with hydraulic tilt & angle (Six-way)
- Angle dozer (Six-way), wide (LGP)
- Ripper, multi-shank (provision for 5 teeth)
- Hitch, retrieval

Overall tractor

- Heavy duty, louvered radiator guard door
- Protection guard for fuel tank and filler
- Engine hood, solid
- Engine side doors, perforated
- Engine hood, perforated
- Fuel tank bottom guard
- Crankcase guard with pull hook
- Radiator, fan and transmission guards

Note: Standard equipment Optional attachments



DRESSTA

Kwiatkowskiego 1, 37-450 Stalowa Wola, POLAND

tel.: +48 15 813 52 52, 15 813 45 56

fax: +48 15 813 47 63

sales@dressta.com.pl

www.dressta.com.pl

Specifications subject to change without notice. Illustrations may include optional attachments and accessories and may not include all standard equipment.